

# MODEL 16A T/S

SERIAL No.

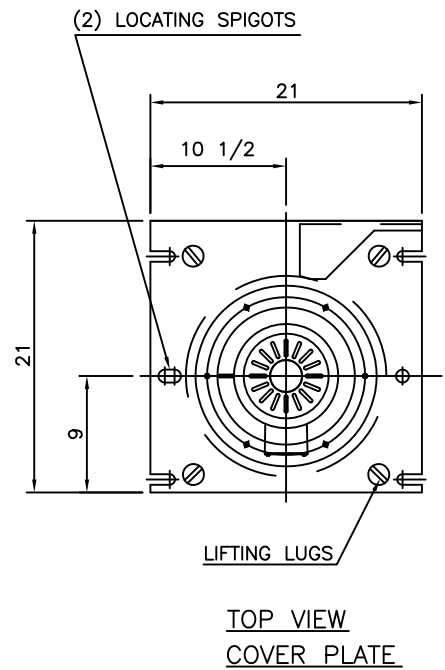
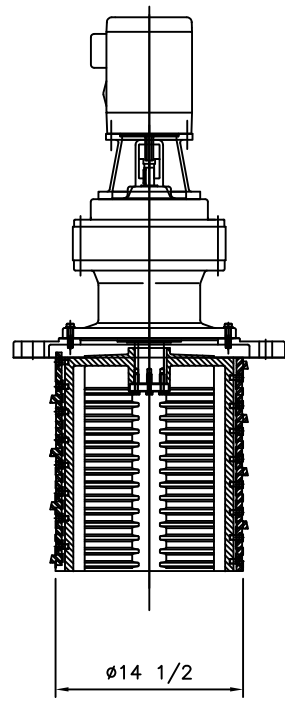
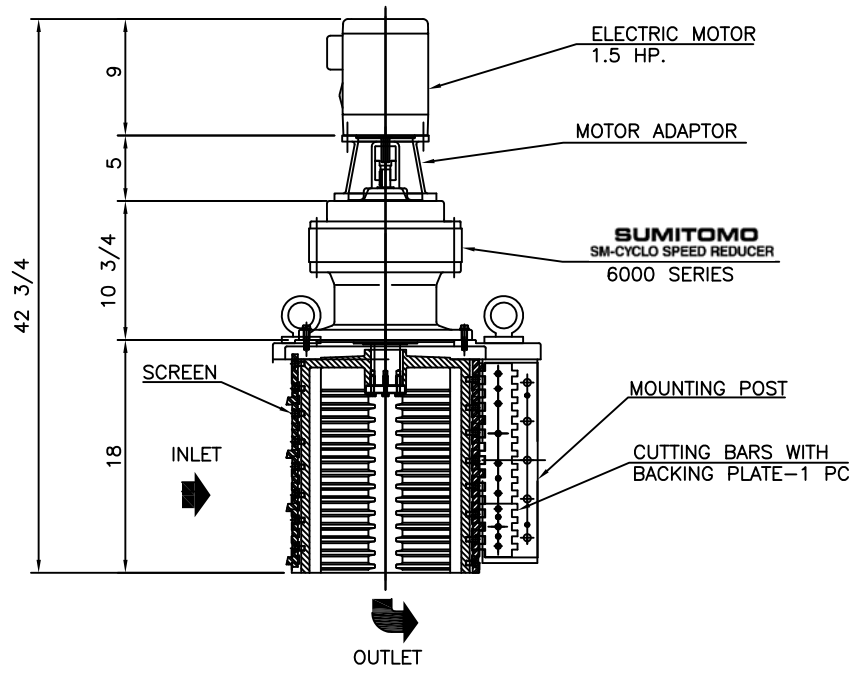

### MATERIALS OF CONSTRUCTION & GENERAL ENGINEERING DATA

HOUSING:	GREY IRON	CAPACITY	3.5 MGD (US) / 13200 m3/ day	INLET AREA	202 SQ IN	1303 cm sq
DRUM (SCREEN):	DUCTILE IRON (ASTM 536 GRADE 60-45-18)	DRUM SPEED	30 RPM	OUTLET AREA	121 SQ IN	780.6 cm sq
SHEAR BARS:	AISI-A2 HIGH ALLOY TOOL STEEL	ROTATION	CLOCKWISE	DRUM DIAMETER	14.5 IN	36.8 cm
CUTTING BARS:	AISI-01 TOOL STEEL REVERSIBLE	SLOT WIDTH	.470 IN / 12 mm	WEIGHT	750 LB	340 kg
HARDWARE & FASTENERS:	304 STAINLESS STEEL	No. OF SLOTS	56			
MOTOR MANUFACTURER:		POWER:	- / - / -	RPM:	1750	REDUCER: SM - CYCLO
STYLE:	TEFC	HP:	1.5	KW:	1.12	MODEL: V6160 / 65
		FRAME:	56C	FLANGE:	56C	RATIO: 59:1
						RATING: 7.72 HP

NO.	DATE	BY	REVISION
-	-	-	-

**G.E.T. INDUSTRIES INC.**  
 get@grindhog.com  
 www.grindhog.com  
 1 (877) 213-7418

TOLERANCES	INFO	SCALE	
DECIMAL		NTS	
FRACTIONAL		DRAWN BY	
ANGULAR		G.P.	
DATE	FILE NO.	DWG. No.	REV.
		6 0226	-

# Grind Hog<sup>TM</sup>

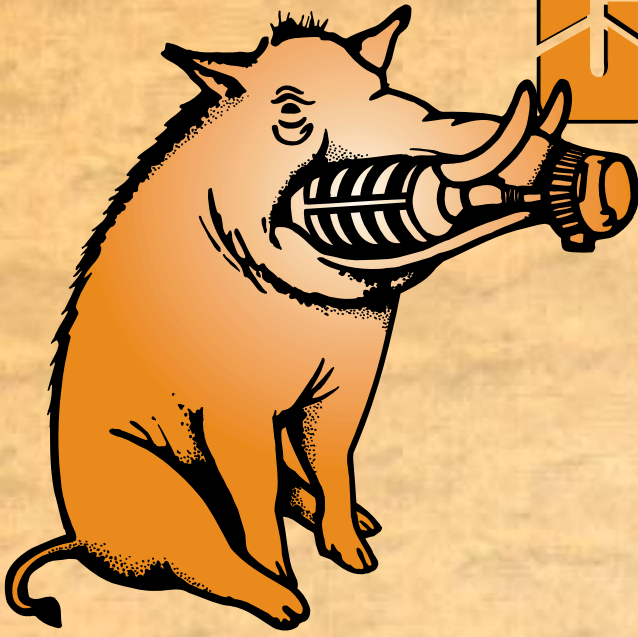

## RETROFIT

Worthington Model 20



GRIND HOG 16A T/S

**Existing Worthington Model 20 removed and Grind Hog 16A T/S installed within one day**



Worthington Model 20



GRIND HOG MODEL 16 A T/S





# HORIZONTAL FLOW

RETROFIT ALTERNATIVE

## “TOILET SEAT BOX STYLE” DROP IN REPLACEMENT

PROJECT: \_\_\_\_\_

ANTICIPATED PEAK FLOW: \_\_\_\_\_

EXISTING CHANNEL:

Width (w): \_\_\_\_\_

Depth (d): \_\_\_\_\_

Underdrain Clearance (c): \_\_\_\_\_

MOTOR REQUIREMENTS:

Power: \_\_\_\_\_ / \_\_\_\_\_ / \_\_\_\_\_

Enclosure: \_\_\_\_\_

Replaceable wear ring for extended life

Supported from above on the channel walls, eliminating the requirement for any submerged anchorage

Fabricated from 304 Stainless Steel to suit existing channel dimensions

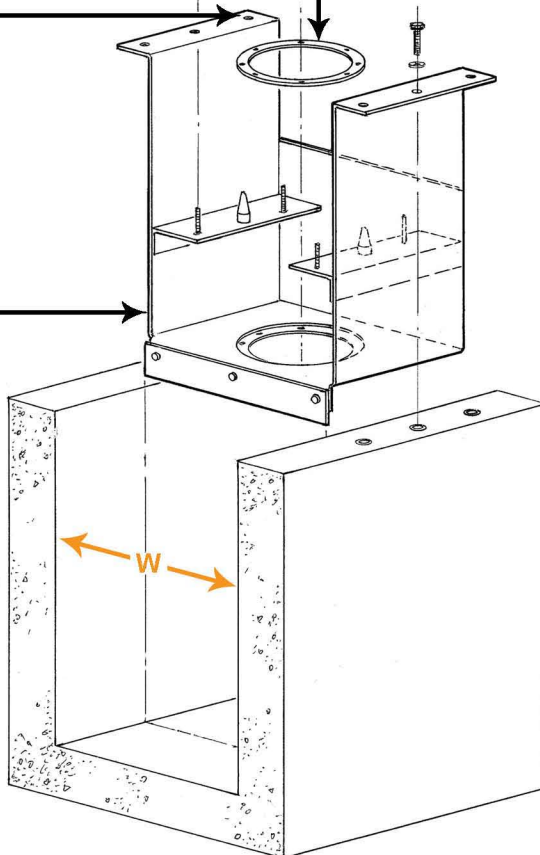
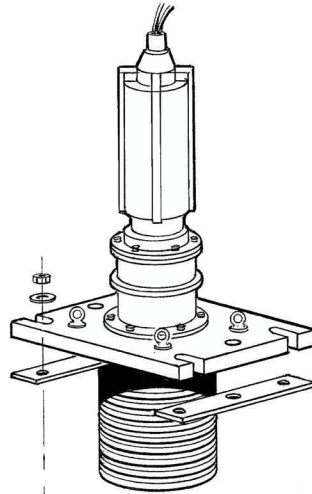

## REPLACING

Barminutor

Infilco Degremont

Clow Aer-O-Flo

Muffin Monster

Franklin Miller-Diminutor

Worthington

.....Among others

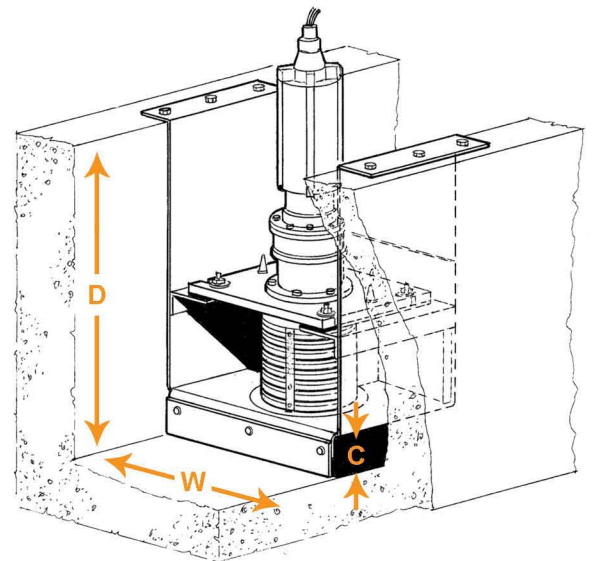

# HORIZONTAL FLOW



Customized to suit each application

## ORIGINAL CHANNEL

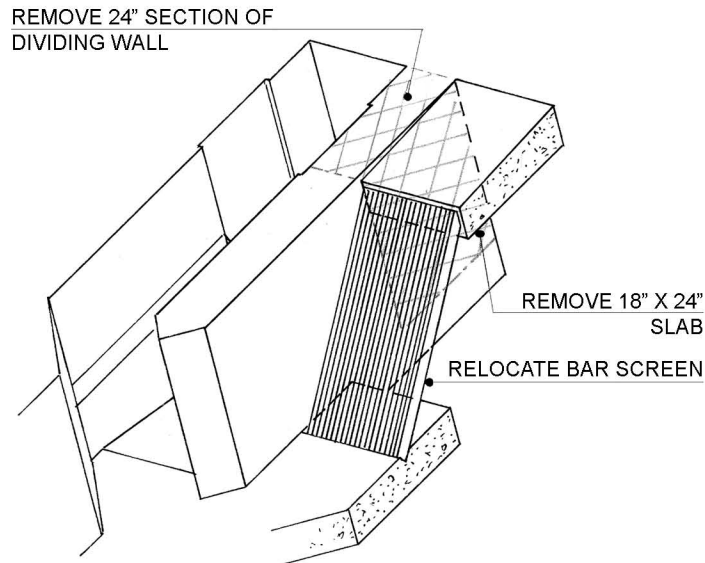

## PROPOSED CHANGES

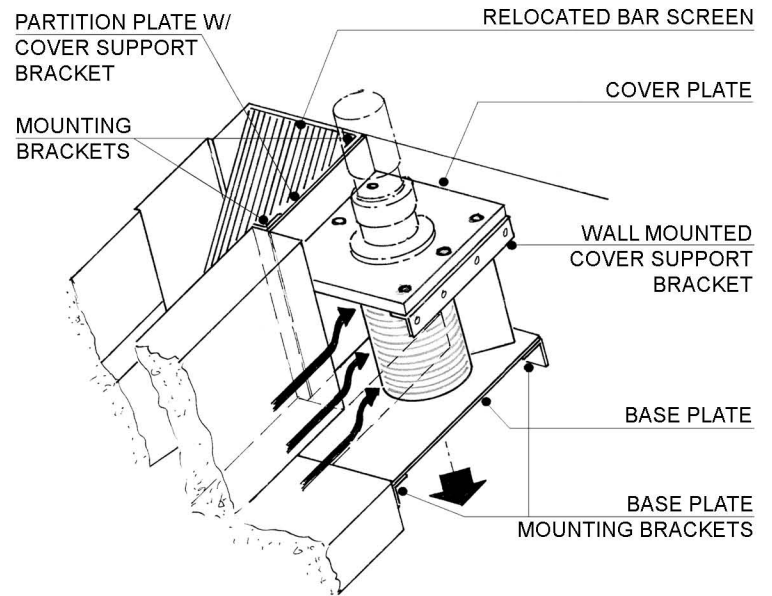

Original  
Worthington 15-5



Custom Fabricated  
Basin



16 ASX T/S



Custom Fabricated Basin  
& 16ASX T/S  
Ready for Shipment

G.E.T. INDUSTRIES INC.

Toll free: (877) 213-7418

Email: [get@grindhog.com](mailto:get@grindhog.com)

Web: [www.grindhog.com](http://www.grindhog.com)